

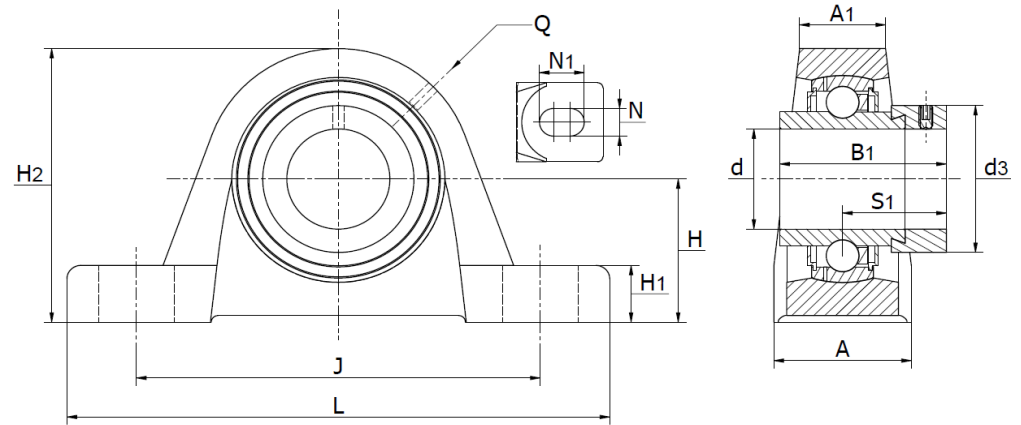

SW .. A series (RASE) - Plummer block housing units

cast iron housing, radial insert ball bearing with eccentric locking collar



Part No.	d mm	Dimensions (mm)													Bearing No.	Weight (kg)	Cover
		L	H ₂	A	A ₁	B ₁	d _{3 max}	H	H ₁	J	N	N ₁	Q	S ₁			
SW 20 A-RASE20	20	130	64,0	32	19	43,7	33,0	33,3	14,5	97	11	19	R1/8	26,6	HC 204	0,59	N/A
SW 25 A-RASE25	25	130	70,0	36	22	44,4	37,5	36,5	14,5	103	11	19	R1/8	26,9	HC 205	0,70	KASK05
SW 30 A-RASE30	30	158	82,0	40	25	48,4	44,0	42,9	17,0	118	14	22	R1/8	30,1	HC 206	1,11	KASK06
SW 35 A-RASE35	35	163	93,0	45	27	51,1	51,0	47,6	19,0	126	14	21	R1/8	32,3	HC 207	1,60	N/A
SW 40 A-RASE40	40	179	99,0	48	30	56,3	60,3	49,2	19,0	138	14	26	R1/8	34,9	HC 208	1,83	KASK08
SW 45 A-RASE45	45	192	107,0	48	32	56,3	63,0	54,0	21,5	150	14	29	R1/8	34,9	HC 209	2,21	Cover Ø45
SW 50 A-RASE50	50	200	115,0	54	34	62,7	69,0	57,2	21,5	158	18	23	R1/8	38,1	HC 210	2,70	KASK10
SW 55 A-RASE55	55	222	124,5	60	35	71,4	76,0	63,5	22,5	176	18	30	R1/8	43,6	HC 211	3,40	N/A
SW 60 A-RASE60	60	240	140,0	60	42	77,7	84,0	69,9	25,0	190	18	28	R1/8	46,8	HC 212	4,79	KASK12
SW 65 A-RASE65	65	260	156,0	65	44	66,0	96,0	79,4	27,5	203	22	28	R1/8	44,6	HC 213-214	6,41	N/A
SW 70 A-RASE70	70	260	156,0	65	44	66,0	96,0	79,4	27,5	203	22	28	R1/8	44,6	HC 214	6,15	N/A
SW 75 A-RASE75	75	265	164,0	66	44	67,1	100,0	82,5	27,5	217	22	28	R1/8	45,6	HC 215	7,65	N/A
SW 80 A-RASE80	80	292	175,0	78	52	70,7	108,0	88,9	30,0	232	25	30	R1/8	47,6	HC 216	8,65	N/A
SW 90 A-RASE90	90	327	200,0	88	52	69,6	118,0	101,6	33,0	262	27	36	R1/8	46,6	HC 218	12,12	N/A
SW 100 A-RASE100	100	380	225,0	95	62	75,0	132,0	115,0	40,0	308	30	55	R1/8	49,5	HC 220	15,85	N/A
SW 120 A-RASE120	120	440	265,0	105	70	81,0	152,0	135,0	45,0	358	33	41	R1/8	52,5	HC 224	25,53	N/A